

ELEVATION

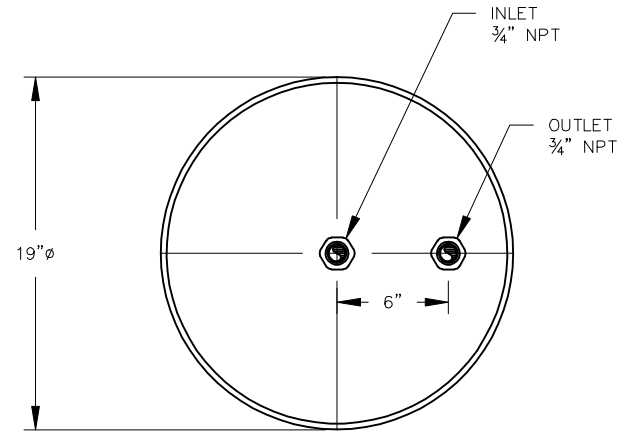

PLAN

2	REVISE PRESSURE RATING	JB	1/2/07
1	REVISE TITLE BLOCK	JB	1/28/03
NO.	REVISION	BY	DATE

PROJECT	
C-5 DRUM	
PROJ. NO.	SALES
P.O. NO.	
<small>THIS DRAWING AND DESIGN ARE THE PROPERTY OF TIGG CORP. AND SHALL NOT BE REPRODUCED IN WHOLE OR IN PART, NOR EMPLOYED FOR ANY PURPOSE OTHER THAN SPECIFICALLY PERMITTED IN WRITING BY TIGG CORP. THIS DRAWING LOANED SUBJECT TO RETURN ON DEMAND.</small>	
DRAWN BY	ZS
DESIGN BY	BL
CHKD. BY	BL
DATE	10/12/99
SCALE	NTS



PLAN & ELEVATION

DWG. NO.	C-5-1001	REV.	2
----------	----------	------	---

VESSEL STANDARDS

VESEL MATERIALS : CARBON STEEL	VOLUME OF VESSEL : 30 GAL.
LINING : DOUBLE EPOXY / PHENOLIC	MAXIMUM MEDIA FILL : 4 FT ³
EXTERIOR PAINT : ACRYLIC ALKYD ENAMEL	SHIP WT. (EMPTY) : 40 LBS
INTERNALS : SCH 40 PVC	MAXIMUM OPERATING PRESSURE : 10 PSIG
ADSORBENT OUTLET ASSEMBLY : N/A	MAXIMUM OPERATING TEMPERATURE. : 130'
LIQUID DRAIN ASSEMBLY : N/A	